

Promenade Vinyl Window Box

Description

- Made from 100% high-grade polyethelene
- Features a double wall design creating a water reservoir
- Includes 3 wall mount brackets with a black powder coated finish
- Warranty: 15- Yr residential use/ 5- Yr Commercial use

Product Dimensions

Outside Dimensions: 48"L x 11"H x 10.8"H (121.9cm x 27.9cm x 27.4cm)

Inside Dimensions: 44.4" x 7.4"W x 8"D (112.9cm x 18.9cm x 20.3cm)

Soil Capacity: 10 Gallons (37.8 Liters)

Water Reservoir Capacity: 4 Gallons (15 liters)

Wall Thickness: 0.125" (3.17mm)

Part Weight: 20lbs. (9.1 kg)

Material: Polyethelene

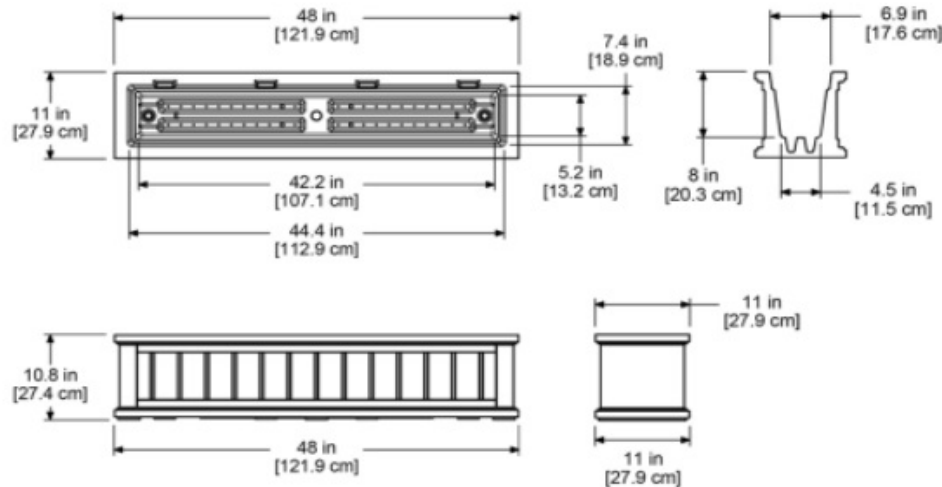

GENERAL NOTES

--

 6056 Corte Del Cedro, Carlsbad CA 92011 1-888-320-0626/service@plantersunlimited.com www.plantersunlimited.com	PRODUCT DESCRIPTION		SKU		ORDER NUMBER	CUSTOMER SIGNATURE	
	Promenade 48" Window Box		M7-4841				
	DIMENSIONS	COLOR	FINISH	REP:	DB:	DATE	

